



NEW GENERATION INVERTER BLDC HIGH PERFORMANCE CHILLER UNIT



ADVANTAGE OF USE

- Very compact design and low weight
- 50% higher energy efficiency compared to ON/OFF
- Highest comfort: silent operation and stable temperature
- User friendly touch display
- Elimination of peak current at start-up (only 2 A max)
- Suitable for severe-duty conditions (military applications)

EASY INSTALLATION

The compact overall dimensions and low weight allow the installation onboard all types of boat

SEAWATER HEAT EXCHANGER

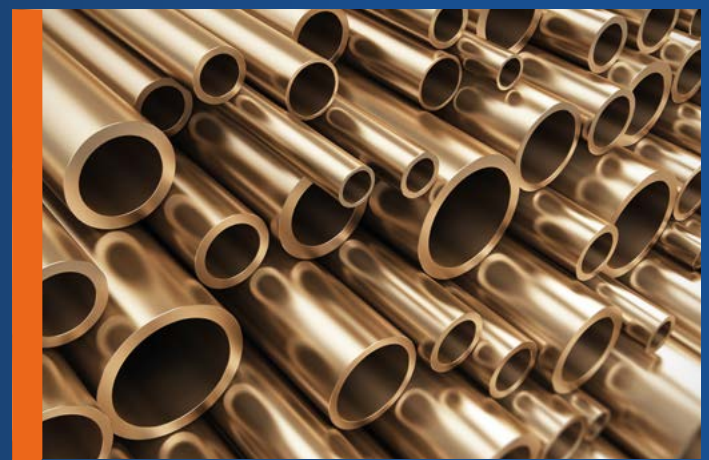

Special Cu-Ni 70/30 seawater condenser offering the highest resistance to erosion and corrosion.

NEW BLDC INVERTER GENERATION SMALLER, LIGHTER AND MORE POWERFUL



ADJUSTABLE HYDRAULIC CONNECTION

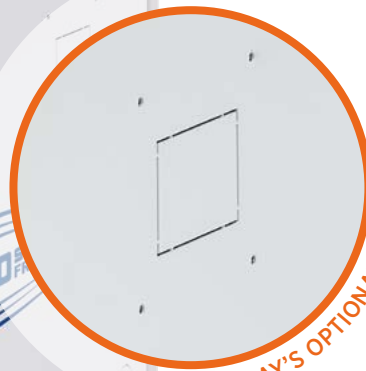

DISPLAY'S OPTIONAL POSITION



TOUCH SCREEN

TOUCHSCREEN THERMOSTAT

THE FIRST MARINE AIR CONDITIONING SYSTEM WITH THE BLDC INVERTER TECHNOLOGY

ULTIMATE INVERTER BLDC TECHNOLOGY

VFD technology "sensor less" is used to accurately control the compressor speed in order to deliver the needed capacity at all times, following the environmental conditions; by contrast traditional air conditioners use on/off type compressors that either work at maximum speed or stop.

The Frigomar chiller unit is equipped with a BLDC motor compressor (98% energy efficient) controlled by an electrical inverter varying the speed from 20-100 Hz.

Thanks to the elimination of start-stop cycles the energy efficiency is considerably increased without sharp fluctuations of water temperature and power supply, thus increasing the lifespan of the unit and the comfort on board.

ENERGY SAVING (-50% ON AVERAGE ELECTRICAL ENERGY CONSUMPTION)

Compressor starts at low speed (20 Hz) with no peak current and then accelerates smoothly up to the max frequency (100 Hz) in order to cool or heat quickly. As water temperature approaches the set point value, the compressor slows down, keeping a constant temperature in silent operation and saving energy. In term of Seasonal Energy Efficiency Ratio, the average reduction in electrical energy consumption is 50%, compared to the equivalent traditional air conditioner.

SMOOTH STARTING (NO PEAK CURRENT AT START)

Starting ramp is set at low frequency (20 Hz) allowing very low starting torque and starting current, far below the nominal value.

The max starting current is 2 A, while for the equivalent traditional air conditioner the max peak starting current is 70-80 A, despite employing soft starting devices.

POWERFUL (SHORT PULL-DOWN PERIOD)

Inverter air conditioning operates at maximum capacity after start up, therefore the set temperature is reached more quickly.

COMFORTABLE

Inverter air conditioner finely adjusts its capacity according to the thermal loads variation in order to maintain the desired ambient temperature without fluctuations, thus allowing higher comfort than with non-inverter air conditioners. Thanks to PMSM motor and sound shields design the operation is very silent in every working condition. Twin rotary compressor allows to reduce vibrations by 75% compared to traditional units.

VARIABLE CAPACITY OPERATION (ECO MODE)

ECO function can be activated from the controller limiting the max compressor frequency, thus reducing further the power consumption.

RELIABLE

BLDC motor together with accurate control of superheating allow a much longer compressor lifespan than non-inverter models, where start / stop cycles stress considerably the motor windings.

Thanks to VFD exclusive technology the unit withstands engine room temperature up to 70 °C (158 °F), low seawater temperature (5°C/41°F) in winter and high seawater temperature (45°C/113°F) in summer.

EASY INSTALLATION

Very compact dimensions with possibility to install more units in parallel. The touch display can be detached from the unit and located at a distance up to 50 m (164 feet) through a Belden cable.

COMPLY WITH EMC DIRECTIVE

The equipment complies with the Electromagnetic Compatibility (EMC) Directive 2004/108/EC.

DESIGNED AND MANUFACTURED IN ITALY

In ISO 9001:2015 certified factory.



CU50VFD

Max Cooling/Heating capacity

50.000 BTU/h

Dimensions

330 x 418 x 477 mm

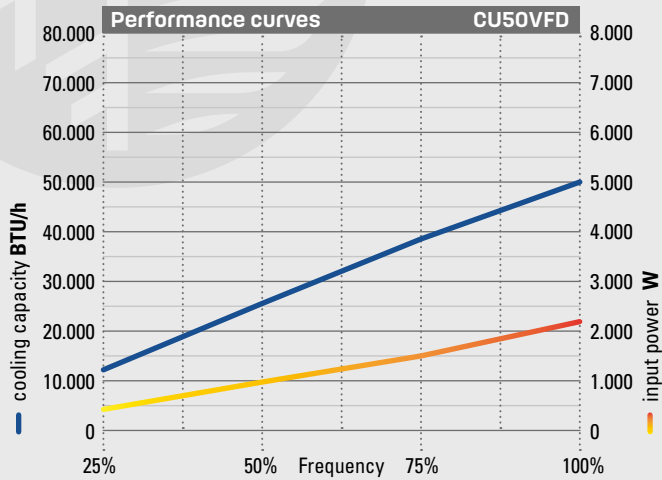

MODEL

MODEL	CU50VFD
Width	330 mm - 13 in
Height	418 mm - 16.5 in
Depth	477 mm (+100 mm pipe) - 18.8 in (+3.9 in pipe)
Weight	55 kg - 121 lb
Voltage/phase/ cycle	230 V / 1ph / 50-60 Hz
Max Cooling/Heating capacity	50.000 BTU/h - 4 ton
Max input power	2,2 kW
Max Current	10 A
Cooling capacity ECO (factory set value)	18.000 BTU/h
Input power ECO mode	0,85 kW
Seawater flow - pressure drop	1,8 m ³ /h - 6,5 m H ₂ O - 475 gph - 21 feet H ₂ O
Fresh water flow - pressure drop	1,5 m ³ /h - 2,8 m H ₂ O - 396 gph - 10 feet H ₂ O
Refrigerant R410A	0,75 kg - 1.65 lb

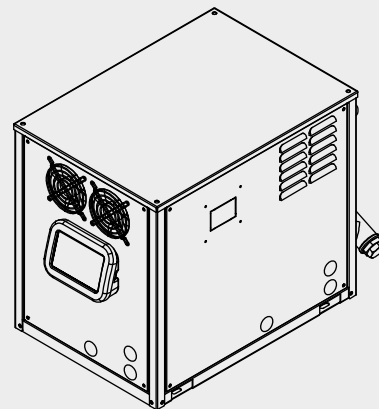
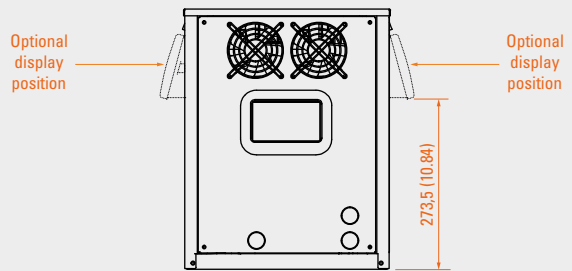
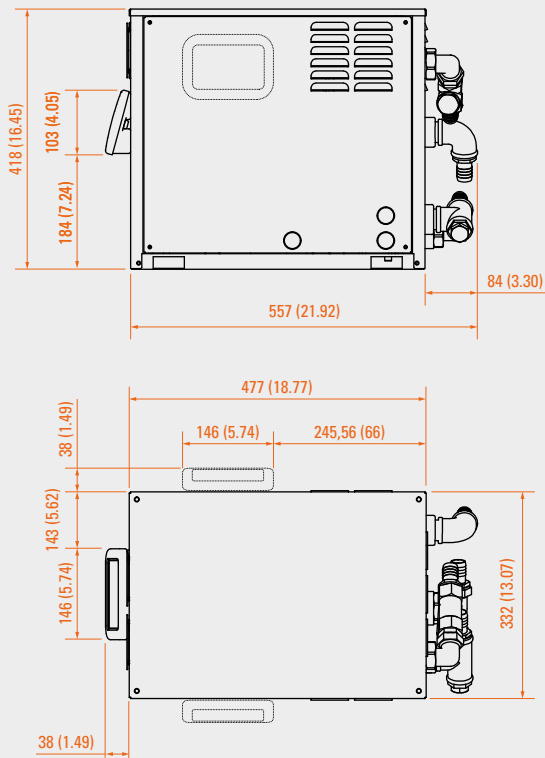

Dimensions in mm (inch)

CU70VFD

Max Cooling/Heating capacity
70.000 BTU/h

Dimensions
430 x 418 x 477 mm

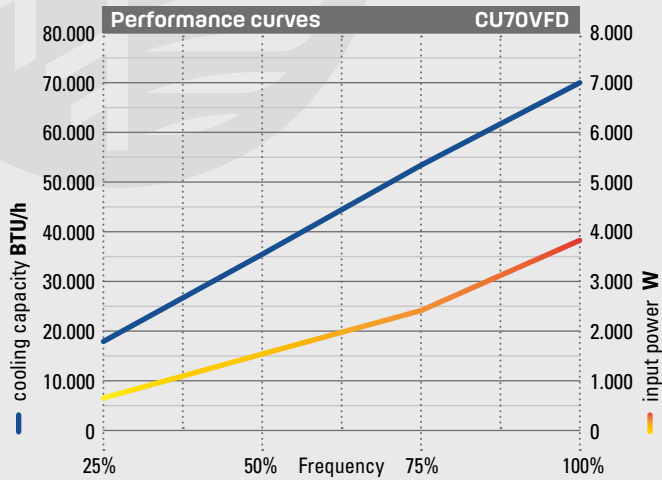

MODEL

MODEL	CU70VFD
Width	430 mm - 17 in
Height	418 mm - 16.5 in
Depth	477 mm (+100 mm pipe) - 18.8 in (+3.9 in pipe)
Weight	64 kg - 141 lb
Voltage/phase/ cycle	230 V / 1ph / 50-60 Hz
Max Cooling/Heating capacity	70.000 BTU/h - 6 ton
Max input power	3,8 kW
Max Current	17 A
Cooling capacity ECO (factory set value)	24.000 BTU/h
Input power ECO mode	1,2 kW
Seawater flow - pressure drop	3,3 m³/h - 6,2 m H ₂ O - 872 gph - 20 feet H ₂ O
Fresh water flow - pressure drop	2,2 m³/h - 6,7 m H ₂ O - 581 gph - 22 feet H ₂ O
Refrigerant R410A	0,9 kg - 1.98 lb

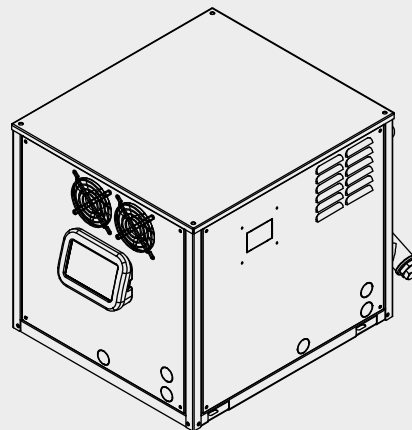
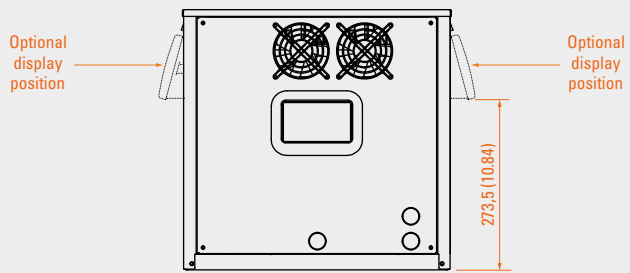
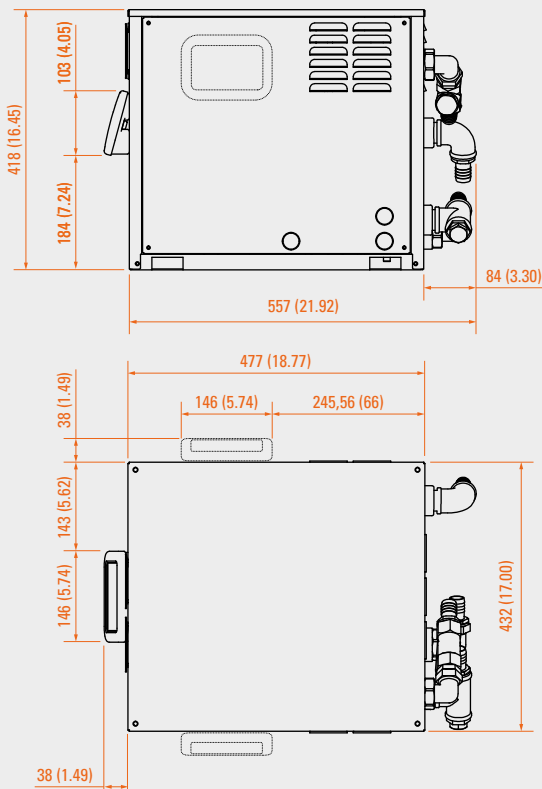

Dimensions in mm (inch)